

## CamTest ColMot

Optical target projectors

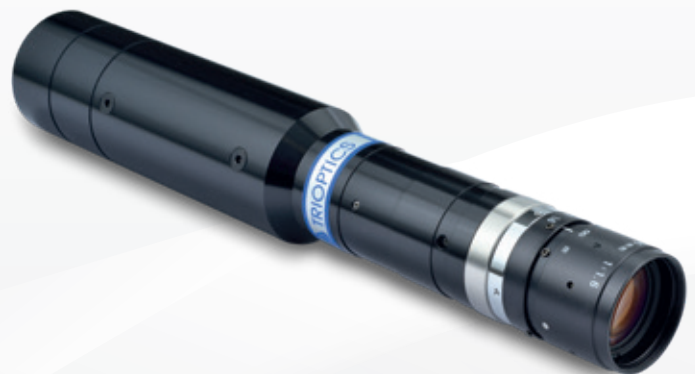

## Passion for optics

---

TRIOPTICS develops and produces the world's largest range of optical measurement and manufacturing technology for the development, quality control and production of lenses, lens systems and camera modules.



## Optical target projectors

The CamTest ColMot system is a series of industry-leading optical target projectors providing virtual test targets for the performance test of electronic camera modules or objective lenses. The main application is the test for camera image quality, lens alignment and focus precision. These motorized focusing

collimators are designed for highest accuracy and robustness in automated in-line test setups with 24/7 availability. Typically, a set of target projectors is arranged around the camera lens pupil to provide test points at significant locations in the field of view of the camera module under test.

### Key features

- Very compact design for dense field of view (FOV) coverage
- Infinite conjugate testing for very wide FOV cameras
- Industrial grade robustness and reliability
- Large variety of LED illumination sources and target patterns
- Closed-loop control for target position and luminance level
- Accurate factory calibration
- High speed and high positioning repeatability
- Software Development Kit (SDK) and drivers available
- For measurement of MTF/ SFR, through-focus MTF/ SFR, image plane tilt, camera boresight, focus setting and roll angle
- Sleek single cable connection

## Operation principle and design

The CamTest ColMot target projector is a very compact opto-mechanical device embodying a high-resolution reticle target, an objective lens for its projection, and a LED illumination. A micro-stepping piezo motor adjusts the reticle distance to the objective lens for projection at user programmable apparent target distances. Both, illumination unit and piezo motor drive include feedback sensors for process control and safety in production environments.

Typically, a multitude of target projectors are arranged around the entrance pupil of a camera under test to have enough test points in the camera's field of view (FOV). The very compact dimensions of TRIOPTICS' ColMot projectors allow for a high number of these test points. In particular, they allow the measurement at infinite conjugate or far object distances with minimum machine footprint compared to alternative test chart setups. Using individual projectors for each field point guarantees consistent high image quality throughout the full image field.

Please ask TRIOPTICS for assistance to find the optimum test configuration and coverage of the FOV by considering the sample's characteristics and mechanical constraints.

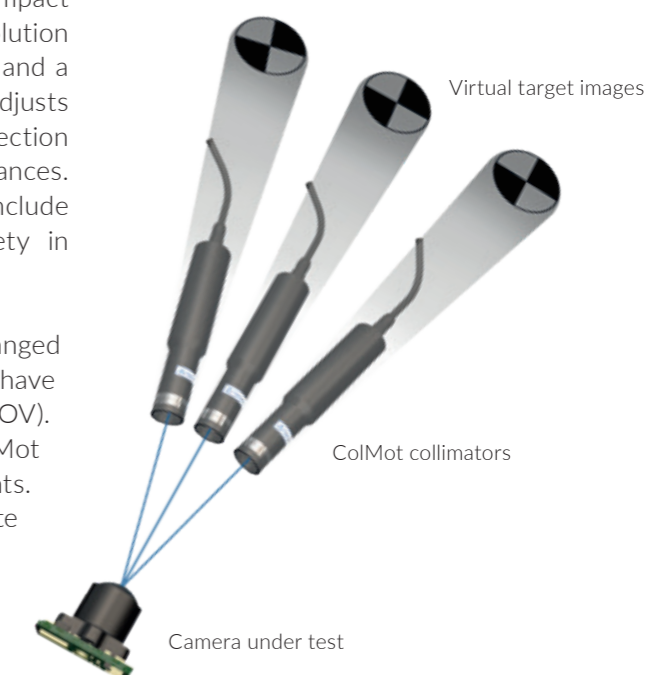

# Basic principle of focusing collimators

Motorized focusing collimators project a real or virtual target image from a selectable distance between infinity and finite distance.

Standard collimator  
Infinity setting

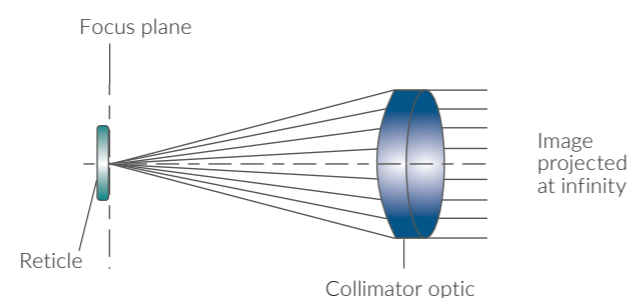

Focusing collimator  
Finite distance setting - Real Image

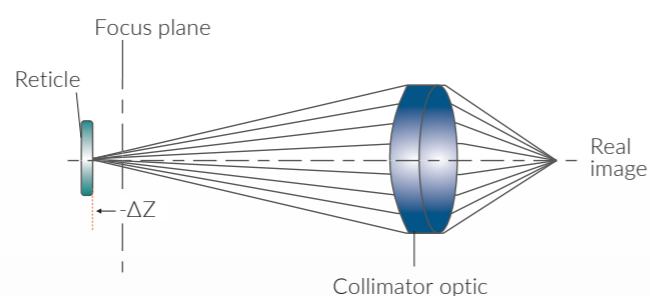

Focusing collimator  
Finite distance setting - Virtual Image

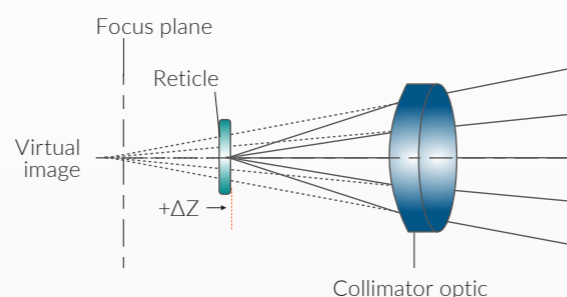

The target projection with each individual ColMot guarantees maximum image quality at every test point and allows for accurate measurements of the modulation transfer function (MTF) or spatial frequency response (SFR) of the sample camera, respectively.

The CamTest ColMot target projector has the industry standard c-mount thread for attaching suitable off-the-shelf machine vision lenses.

Customized lenses are available, too. The focal length of the projector lens will be chosen depending on the focal length of the camera under test. A selection of proven variants is offered as standard configurations. Certain imaging conditions or spectral ranges may require a more adapted selection. In such a case TRIOPTICS will help to find the optimum solution.

The illumination part is largely configurable, too. Based on the application, the engineer can choose between monochromatic LEDs in the visible or near infrared (NIR) spectrum or different white light and RGB LEDs. A color sensor serves as a feedback to the control unit for the right luminance and color spectrum setting. The reticle position relative to the projector lens determines the apparent target distance for the camera under test. This position can be set with sub-micron resolution thanks to the precise piezo motor drive and encoder feedback. Both, the projector lens and LED PCB can be quickly

exchanged by the user to simplify laboratory and evaluation tests. However, in production environments TRIOPTICS recommends staying with the factory calibrated setting, since lens position and color spectrum determine the overall system calibration. All functions of the TRIOPTICS target projectors are controlled by a 19-inch control cabinet connected via USB interface to the application PC. Single channel and multi-channel variants of the control unit are available. Each ColMot projector is connected by a single cable and robust LEMO plugs to the control unit.

Configuration for narrow FOV camera testing



# Applications

TRIOPTICS ColMot focusing projectors are important tools for the image quality assessment of camera modules, both in the development phase as well as in the manufacturing stage.

The internal focus mechanism projects test targets at variable conjugate distances, so that the camera image quality can be verified over a large object distance range. Since these targets are virtually projected, the space requirement of the test setup is significantly smaller than with real test charts, especially when testing wide angle cameras.

The focusing projectors show their greatest benefit in the final inspection of finished fixed-focus camera modules where the lens has already been firmly attached to the camera body. The ColMot focus procedure enables through-focus MTF/SFR testing including the determination of the camera focus setting, maximum contrast, depth of focus and even the tilt of the sensor plane.

Typically, several ColMot projectors are arranged in a dome structure with its epicenter at the entrance pupil of the camera under test, where all projectors are pointing to. In such a setup, the measurement results are obtained simultaneously across the field of view of the camera and the image quality

can be evaluated as a function of the field point. Besides the determination of image quality, valuable information about sample image plane tilt, field curvature and depth of focus is obtained. In addition to these metrology applications for finished cameras, TRIOPTICS ColMot are also often used in the active alignment and assembly of camera modules.

The type of camera, whether narrow or wide field of view, determines the layout of the projector dome. For this layout, the number of projectors of given size, the desired measurement fields and the projector distance to the entrance pupil must be carefully considered. Over the years and in many projects, TRIOPTICS has gained a large experience in this configuration process and we have a large portfolio of proven setups for different camera types.

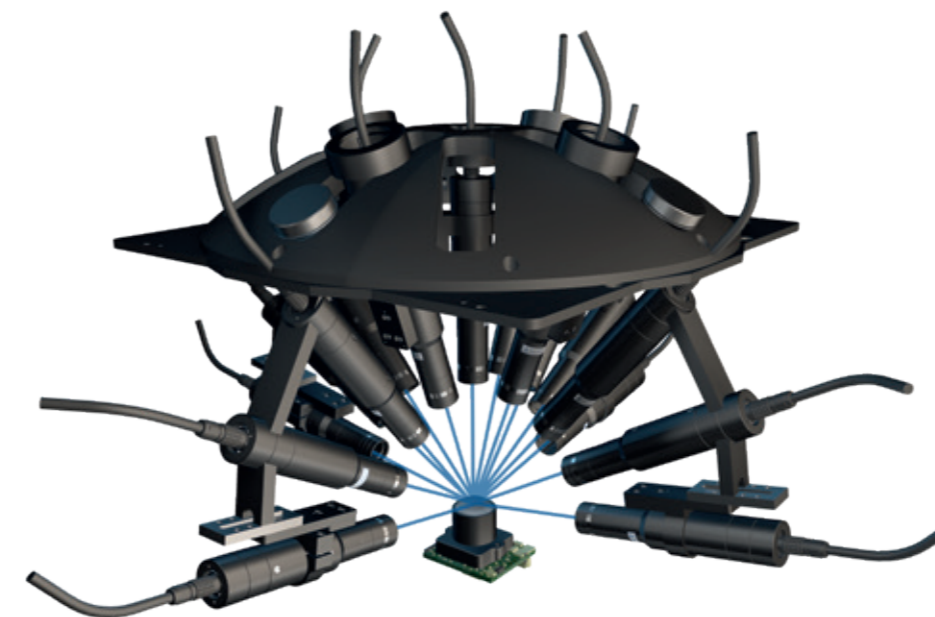

Wide-angle dome for optics with a FOV of up to 180°

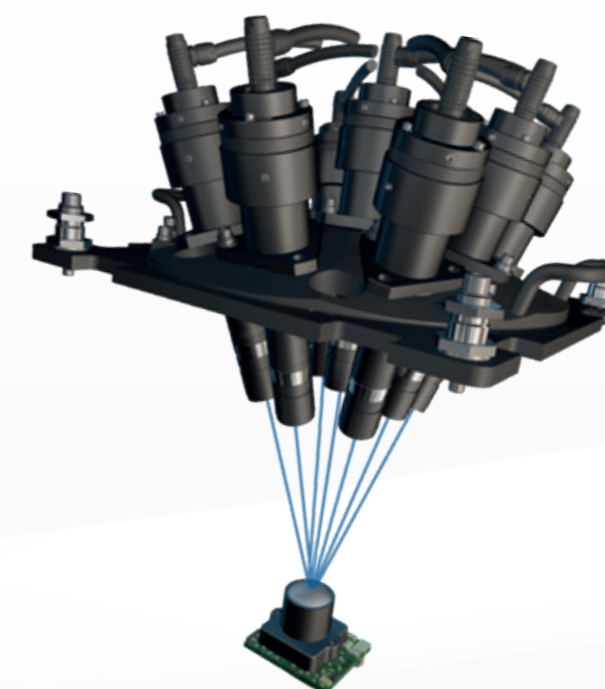

Plug & Produce dome for highest reliability and easy installation of collimators

## Lens, target and illumination options

TRIOPTICS supplies the ColMot equipped with various types of projection lenses with focal lengths between 16 and 150 mm. For optimum results the focal length of the projector should be significantly larger than the focal length of the sample. If the ratio becomes too large, the reduced size of the

projected test pattern will be more difficult to evaluate. Please refer to the specification table for proven configurations. The given ranges shall be considered as recommendations and not as strict obligations. The individual case must be investigated.

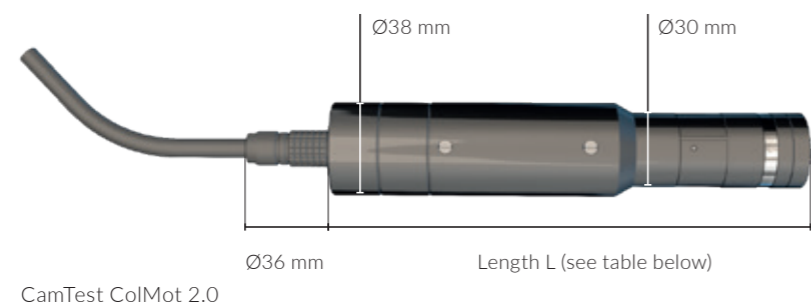

The illumination spectrum of the test targets should reflect the application of the camera under test. Therefore, TRIOPTICS provides a large selection of different LED types of visual and near infrared (NIR) emission spectrum. The basic variants are white LEDs with several color matching filters (RG xx, photopic eye), RGB color mixing LEDs and monochromatic NIR LEDs. The illumination section further

includes a color sensing photodetector for a precise feedback of the luminance level and color characteristics of the controlled LED(s). Tight process control is therefore guaranteed. Please refer to the specification table for standard options and please ask TRIOPTICS for a customized illumination design if the given options do not meet your requirements.

Various target types have become established in camera testing and active alignment applications. The following drawings show the most frequently used variants. Other customized targets can be supplied upon request.

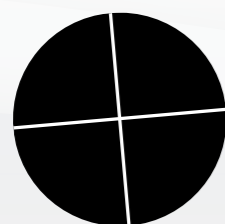

Single crosshair reticle, negative.  
Line width 10 µm or 20 µm

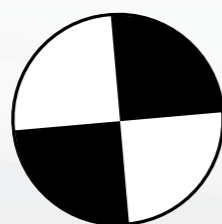

Slanted edge (SFR) reticle,  
four circle segments



Slanted edge reticle (SFR)

## Control unit

A set of ColMot projectors is driven by a common Control Unit, where each device is controlled by a separate command channel. Each channel combines the drivers for the piezo motor and LEDs as well as the readout of the position encoder and the luminance sensor. A master controller takes care of the coordinated command execution and the synchronized timing. Different controller variants with 1, 5 and 9 channels are available which reflect the most common

configurations. For bigger configurations with a higher number of channels, several Control Units can be used parallel. The single channel variant is preferably used in laboratory test setups and evaluation systems. A high-speed USB interface connects the Control Unit to the supervising PC on which the main application is running. A principle sketch of the system layout and its interconnections is shown below.

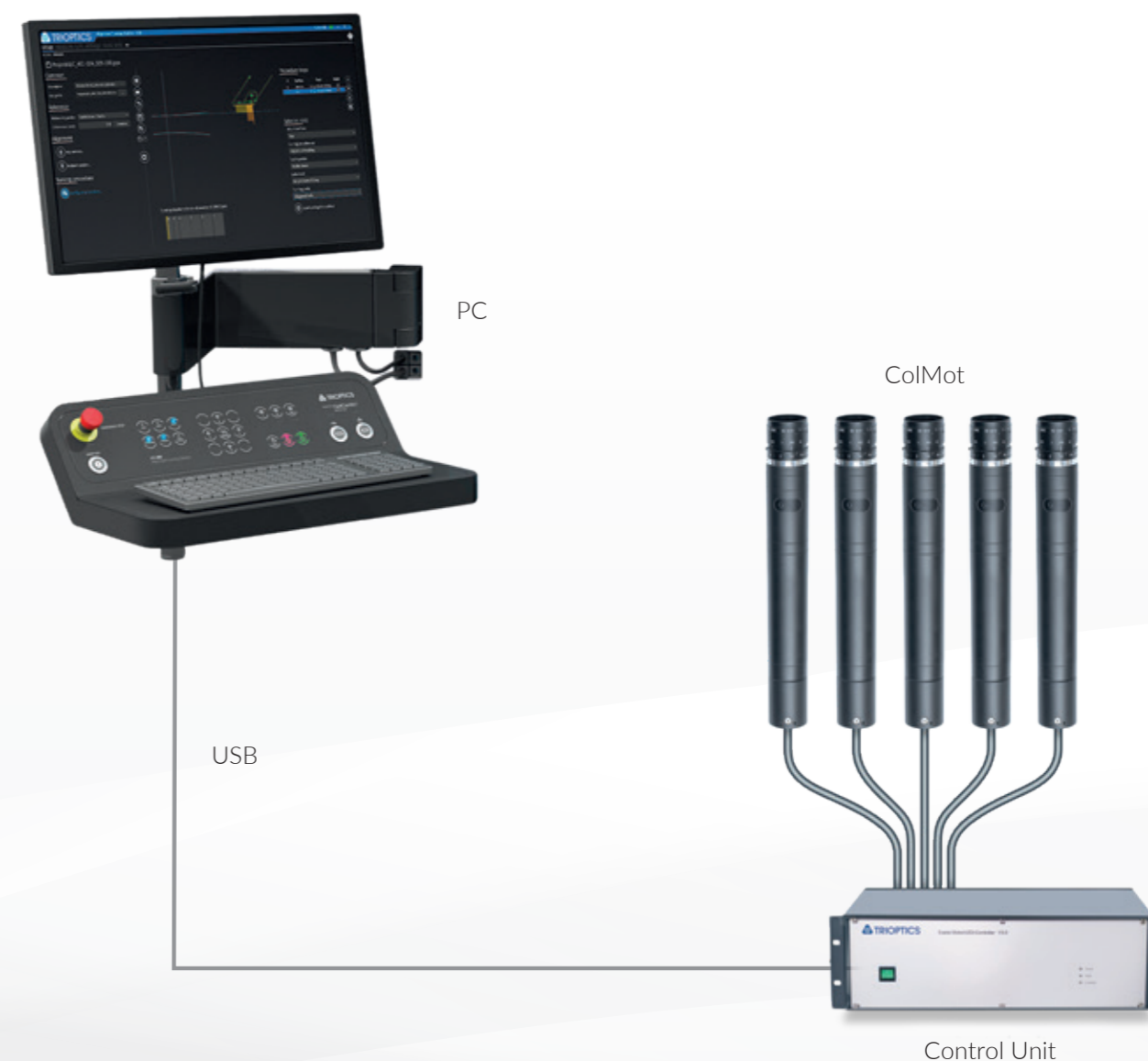

# Specification

## CamTest ColMot 2.0 Series

Type	16	25	35	50	75	100	150
Order number <sup>1)</sup>	16-202-MM-016-YZ	16-202-MM-025-YZ	16-202-MM-035-YZ	16-202-MM-050-YZ	16-202-MM-075-YZ	16-202-MM-100-YZ	16-202-MM-150-YZ
Effective focal length EFL (mm)	16	25	35	50	75	100	150
F-number	1.4	1.3	1.6	2.8	2.8	2.8	5.6
Clear aperture (mm)	11.4	19.2	21.9	17.9	26.8	35.7	26.7
Absolute position accuracy (μm)	< 3						
Position repeatability (bidirectional) (μm)	1.5						
Max. defocusing range ΔZ (mm)	± 9 bidirectional or 18 unidirectional						
Max. speed (mm/s)	5						
Min. adjustable virtual object distance (mm) <sup>2)</sup>	-5	-50	-130	-260	-660	-1100	-2600
Min. adjustable real object distance (mm) <sup>2)</sup>	50	80	140	280	590	1000	2400
Uncertainty of image position in diopters	0.012	0.005	0.002	0.001	0.0005	0.0003	0.0001
Standard target type	10 mm crosshair reticle (10 μm slit width/ 20 μm slit width) 10 mm slanted edge reticle (4-quadrant reticle)						
Standard illumination	White LED (5500 K CT, 6500 K CT) with or without PE <sup>3)</sup> filter RGB LED 850 nm NIR LED 940 nm NIR LED Standard D65 LED						
Color sensor	Closed-loop control for the collimator illumination (intensity and spectral distribution)						
Motor drive	High resolution stepping Piezo motor drive closed loop						
Connector	LEMO 25-pin plug straight or right angle						
Cable length (m)	3 or 5						
Length (mm)	222.4	221.4	229.7	224.0	254.8	259.4	266.3
Weight	300 g (excluding cable, without objective lens)						
Mounting	Ø 38 mm ± 0,2 mm all-round clamping						

1) Please ask for the Requirement Specification Form (RSF); MM: target type; YZ: cable plug

2) Working distance between collimator and Entrance Pupil of Camera Under Test

3) PE = Photopic Eye Filter

Subject to change without notice. The information contained in our offer and our order confirmation shall be decisive.

# Operational

## CamTest ColMot 2.0 Series

Type	16	25	35	50	75	100	150
Compliance	EN 61000-6-4 (2007) +A1 (2011) EN 61000-6-2 (2005) EN 61000-4-2 (2009) EN 61000-4-3 (2006) +A1 (2008) +A2 (2010) EN 61000-4-4 (2012) EN 61000-4-5 (2006) EN 61000-4-6 (2014) EN 61000-4-11 (2004)						
Calibrated temperature range	21°C ± 5°C						
Storage temperature	-10°C ... 50°C (non condensing)						

Subject to change without notice. The information contained in our offer and our order confirmation shall be decisive.

# Control unit

## CamTest ColMot 2.0 Series

Type	1-Axis-Controller	5-Axis-Controller	9-Axis-Controller
Order number	16-202-62	16-202-63	16-202-64
Dimensions (h x w x d)	145 mm x 236 mm x 305 mm	133 mm x 483 mm x 315 mm	133 mm x 483 mm x 315 mm
Weight	1.3 kg	1.7 kg	1.8 kg
Housing/ Dimension	1/2 19 inch rack 4 he	19 inch rack 4 he	19 inch rack 4 he
Switchable power supply	115 V or 230 V (Standard 230 V)		
Interface	USB interface for motor control, LED control and RGB sensor feedback		
Software package	ColMotControl und LibColmot (SDK)		
LED status display	Power (ready for operation)   Fault (in case of error)   In Motion (during movement)		
Power consumption	44 Watt <sup>1)</sup>		

1) 5-axis controller + 5 ColMot

Subject to change without notice. The information contained in our offer and our order confirmation shall be decisive.

## Software library (SDK)

TRIOPTICS provides a Software Development Kit (SDK) for Windows based on a C/C++ API, especially for very customized applications and evaluation purposes in laboratory. The SDK implements the full range of functions for the ColMot piezo motor driver and the LED control. It is also useful for customers who already have implemented all camera interfacing and image analysis functions, but still need to control the

focusing target projectors. The API contains all necessary headers, libraries, binaries and a complete interface documentation. It supports 32-Bit and 64-Bit application development. A demo software tool is provided as a reference implementation of the SDK. With this tool the engineer can execute SDK function calls and retrieve their results in a log file.

## Calibration

TRIOPTICS ColMot target projectors are very robust devices with minimal wear over time. The internal closed-loop positioning system with linear encoder guarantees accurate positioning throughout lifetime and under difficult environmental conditions. But depending on the use case and company internal regulations for measurement devices, a regular inspection and recalibration is advised.

In production processes, a weekly or monthly visual inspection for cleanliness and damages from impacts or other improper handling is recommended. TRIOPTICS further recommends a yearly maintenance and recalibration cycle to verify that the performance of the device is still within specification. In most cases, this service is done by qualified TRIOPTICS engineers, either in-house or as factory calibration.

## ProCam® Software

for active alignment, assembly and testing

With the ProCam® software package, TRIOPTICS offers a complete turn-key solution for the most common tasks in camera module testing and manufacturing. The ProCam® software combines the camera module readout, control functions for the ColMot projector system and part handling functions for assembly processes. For the latter also functions for the glue dispense and UV curing process are included. The core of the ProCam® software are the comprehensive image detection and analysis functions with state-of-the-art autofocus and MTF/SFR routines. For special needs, the embedded Python scripting language allows a

full customization of the test and measurement environment. The ProCam® software is based on latest 64-Bit Windows 10 compatible software libraries and is proven in 24/7 manufacturing environments. It is continuously refined to meet the latest camera interfacing standards and frame rates. If no off-the-shelf camera interfacing or frame grabbing electronics is available, TRIOPTICS will assist with the electronics design starting from the sensor's datasheets. A clearly arranged human machine interface (HMI) for measurement data and process visualization as well as data export and database interfacing functions make the software complete.

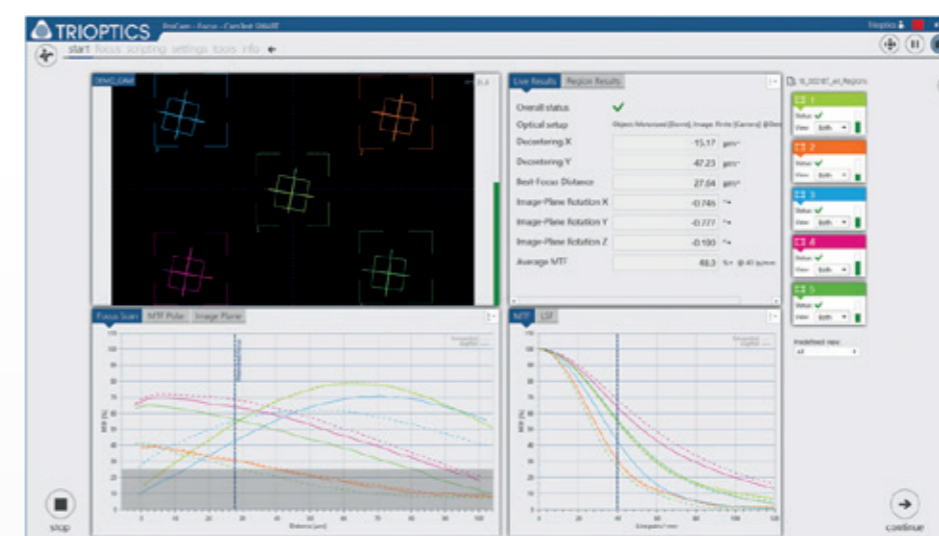

Fully automatic active alignment process with ProCam® software

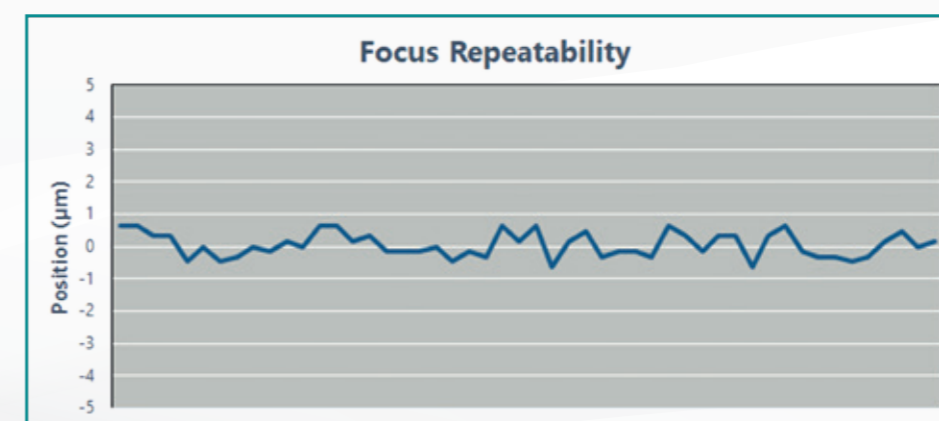

High repeatability in positioning the reticle





# CamTest ColMot 6.0 Series

## high-speed camera production and testing

In many industries, such as the automotive industry, high demands are placed on production to manufacture as many quality cameras as possible in the shortest possible time. Accordingly, the high demands on production also lead to higher demands for the target generators.

### Requirements for target generators in demanding industries:

- High scan speed
- High target quality and positioning accuracy
- Long lifetime, high reliability
- Adjustable to different cameras
- Low maintenance frequency, condition monitoring, fast exchange



The new CamTest ColMot series - called ColMot 6.0 - meets these high requirements and enables the most precise and fastest performance testing available.

Feature	Benefits
Integrated temperature sensor	<ul style="list-style-type: none"> <li>▪ Condition monitoring</li> <li>▪ Process reliability</li> </ul>
Integrated cycle counter	<ul style="list-style-type: none"> <li>▪ Predictive maintenance</li> <li>▪ Plannable machine downtime</li> </ul>
Plug & Produce functionality through EEPROM memory	<ul style="list-style-type: none"> <li>▪ Fast and easy exchange</li> <li>▪ Reduction of operator errors</li> <li>▪ Less downtime</li> </ul>
New controller hardware with new control technology	<ul style="list-style-type: none"> <li>▪ Low cycle time/ faster communication</li> <li>▪ Compact design</li> </ul>
Extended product lifetime (approx. 12,5 Mio cameras can be tested*)	<ul style="list-style-type: none"> <li>▪ Less maintenance</li> <li>▪ Improved lifecycle cost</li> </ul>

\*One scan per camera

Thanks to the new optical target projectors, we increase the performance of our ProCam® alignment systems and CamTest end-of-line testers.

The ColMot 6.0 features an extended product lifetime, resulting in a significant reduction in product life cycle costs. In addition, the new optical target projectors are incredibly fast, which has an optimal effect on the cycle times of our equipment.

In other words, our machines are now even faster, even more accurate, and last forever.

Boost the performance of your camera production with solutions from TRIOPTICS!



CamTest Focus: end-of-line tester

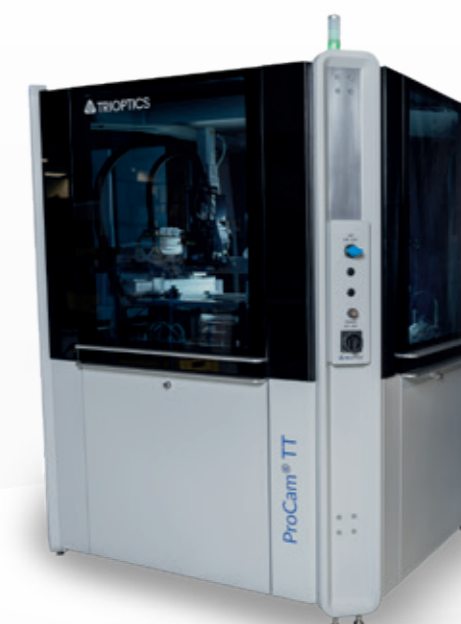

ProCam® TT: full-production system for active alignment

# Specification

## CamTest ColMot 6.0 Series

Type	16	25	35	50	75	100	150
Effective focal length EFL (mm)	16	25	35	50	75	100	150
F-number	1.4	1.3	1.6	2.8	2.8	2.8	5.6
Clear aperture (mm)	11.4	19.2	21.9	17.9	26.8	35.7	26.7
Absolute position accuracy (μm)	± 1.5						
Position repeatability (bidirectional) (μm)	± 1						
Max. defocusing range ΔZ (mm)	± 10 bidirectional or 20 unidirectional						
Max. time for full travel range (s)	2.86 (at 20 mm travel range)						
Min. adjustable virtual object distance (mm) <sup>2)</sup>	-5	-50	-130	-260	-660	-1100	-2600
Min. adjustable real object distance (mm) <sup>2)</sup>	50	80	140	280	590	1000	2400
Standard target type	10 mm crosshair reticle (10 μm slit width/20 μm slit width); 10 mm slanted edge reticle (4-quadrant reticle)						
Standard illumination	White LED (5500 K CT, 6500 K CT) with or without PE <sup>2)</sup> filter RGB LED   850 nm NIR LED   940 nm NIR LED   Standard D65 LED						
Color sensor	Closed-loop control for the collimator illumination (intensity and spectral distribution)						
Motor drive	High resolution micro drive closed loop						
Connector	17 pin M12 industrial plug						
Cable length (m)	3 or 5 (1 m cable length fixed per collimator)						
Length (mm)	228.4	227.4	235.7	230.0	256.8	265.4	272.3
Weight	400 g (including 1m cable, without objective lens)						
Mounting	Ø 30 mm ± 0.2 mm all-round clamping						

1) Working distance between collimator and Entrance Pupil of Camera Under Test

2) PE = Photopic Eye Filter

Subject to change without notice. The information contained in our offer and our order confirmation shall be decisive.



Configuration for narrow FOV camera testing



## TRIOPTICS GmbH

Strandbaddamm 6  
22880 Wedel  
Deutschland

+49 4103 18006-0  
sales@trioptics.com  
www.trioptics.com

